



AAM Competition 370Z/G37/FX35 S-Line Axleback Exhaust INSTALLATION INSTRUCTIONS

WARNING FOR INSTALLER OF THIS PRODUCT

*** Product(s) are designed for off-road / competition use only ***

This AAM Competition, LLC product requires above average mechanical ability to install properly. Installation requires the appropriate tools for tightening and loosening nuts and bolts involved for the installation of this kit. As with all mechanical projects, take appropriate precautions for your personal safety and for the proper care and treatment of the vehicle being serviced. Be sure and read through all directions before attempting.

Copyright AAM Competition, LLC 2014

IF PRINTING, PLEASE DO SO IN COLOR TO BETTER SEE ILLUSTRATIONS WHICH HAVE COLOR CODED ARROWS.

Tools

- Metric socket set
- SAE socket set
- Metric wrench set
- Silicone Lubricant
- Rust Penetrant
- Anti Seize

Parts List

- AAM Competition Axleback Muffler Section (x1)
- AAM Competition Axleback Tips (x2)
- 3/8 Bolts (x4)
- 3/8 Nuts (x4)
- 3/8 Washers (x4)
- 2.5" T-Bolt Clamps (x2)

Instructions

1. Jack vehicle up to gain access to the exhaust system. Make sure to secure the vehicle on jack stands or use a lift.
2. Inspect the OEM system and run through the components to be replaced. The OEM rear muffler is a single piece and is completely replaced by the AAMC Stainless Axleback.
3. Spray the rust penetrant onto the OEM nuts that secure the OEM Axleback to the midpipe. Allow to soak. This may aide in dis-assembly (Label A on the diagram)
4. Unbolt the 4 nuts.
5. Unbolt the one exhaust hanger on the drive side of the OEM exhaust system (Driver side, towards the front of the car) (#4 on the digram) This will not be re-used.
6. The OEM muffler now hangs by two hangers - slip muffler out of the silicone hangers. It helps to use silicone spray. (#2 on the diagram).

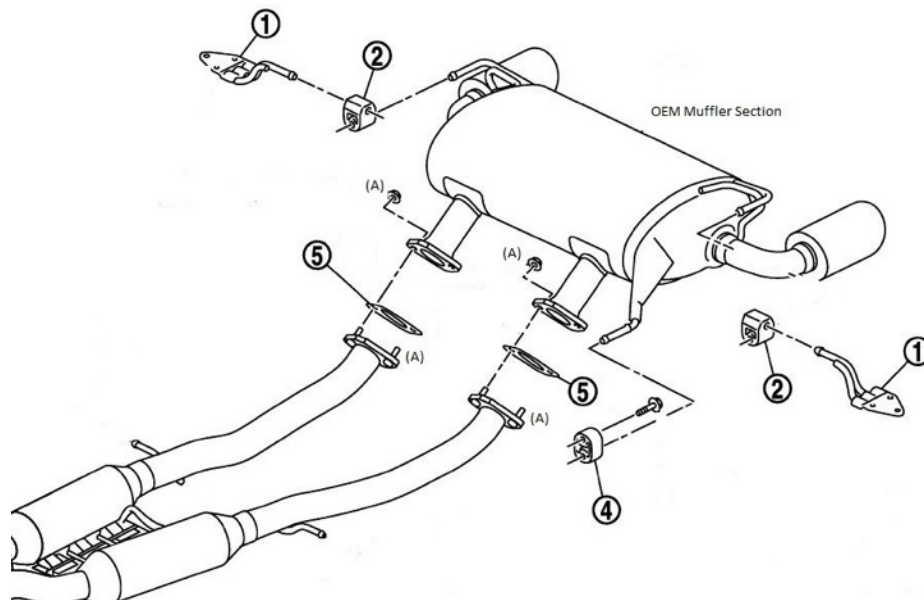

AAM Competition Axleback Installation

- Clean up threads and nuts from dis-assembly. Clean up gasket surface on the OEM Midpipe. (if installed with aftermarket midpipes, use supplied hardware). Spray silicone hangers with silicone lubricant to make installation easier.
- Install the supplied gasket onto the OEM midpipe.
- Carefully install the AAMC Axleback system into the vehicle. Slide into hangers (#2 on the diagram).
- Align and mate the flanges accordingly. Make sure gasket is in place.
- Re-install the nuts. Use antiseize to prevent rusting and seizing down the road.
- Slide on the tips and using the supplied clamps - secure the tips to the muffler section. Tips can be adjusted as needed. We recommend aligning the outer most tip edge with the line of the bumper.
- Tighten all clamps and nuts.

